

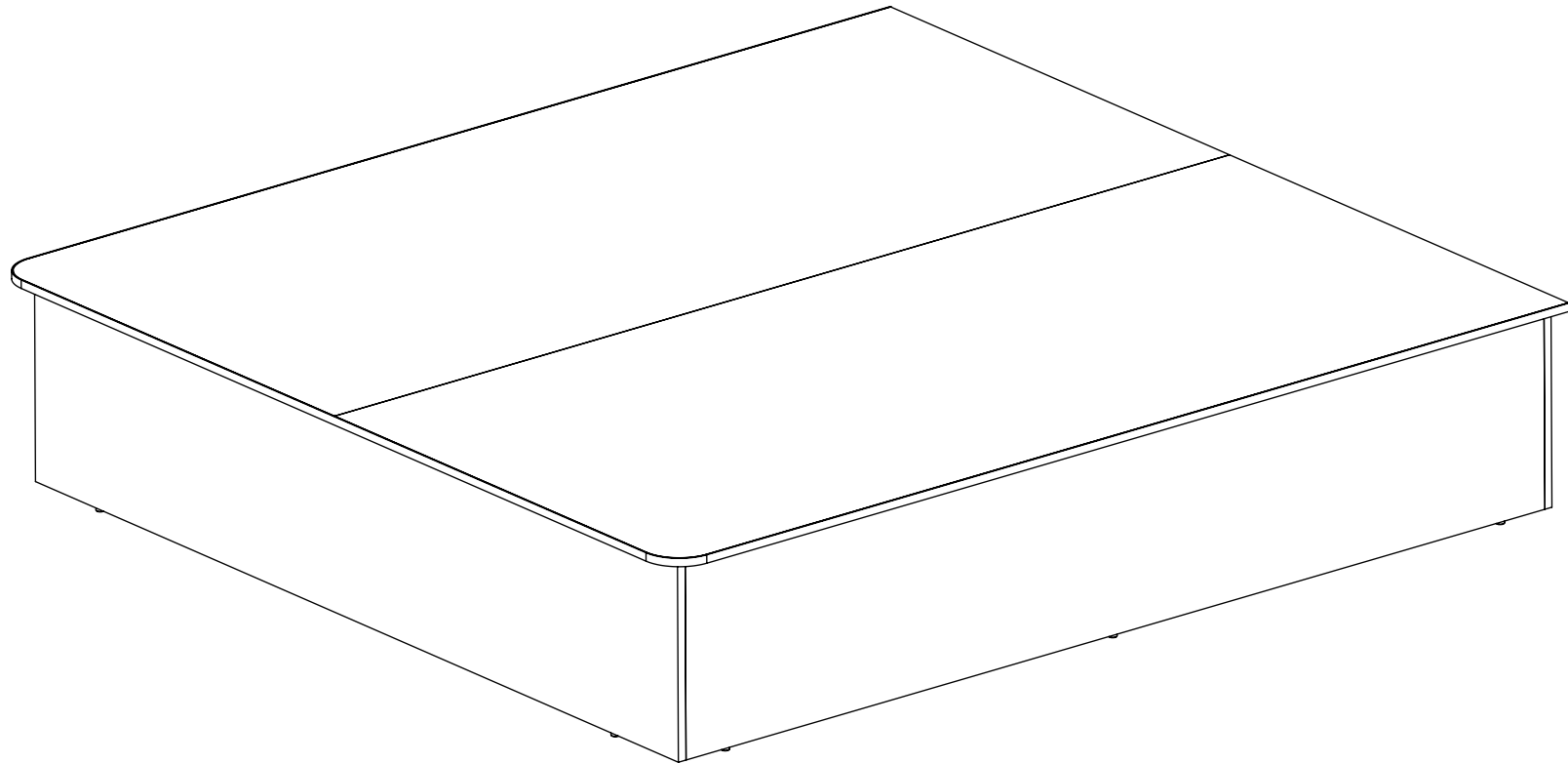

EXPECT
Furniture Manufacture



Overall:
75"W x 80"D x 16"H

MATERIALS:
- HP-Laminate PLY-5/8" Side Panels
- Plywood 5/8" Top Panel
- T-Mold Edge On Top
- Nail Glide On Bottom
- Wood Framing Support

COMMENTS:
- **Overall:** 75"W x 80"D x 16"H
- **Color:** Wilsonart - 0000 - Custom Laminate
- **Note:** Dimensional Tolerance +/- 1/16"

TITLE: AHF 0100XX 6BB - 100Sable - King Bed Base 2" Lip
REVISION DATE: 4/7/2022

NOTE: DESIGN AND DRAWINGS ARE PROPERTY OF DICKSON FURNITURE MANUFACTURERS LLC AND MAY NOT BE DUPLICATED OR REPRODUCED WITHOUT THE EXPRESS WRITTEN CONSENT OF DICKSON FURNITURE MANUFACTURERS LLC

QUANTITY
00

REV
A

DIMENSIONS
ARE IN
INCHES

SCALE: 1:13

SHEET 1 OF 5

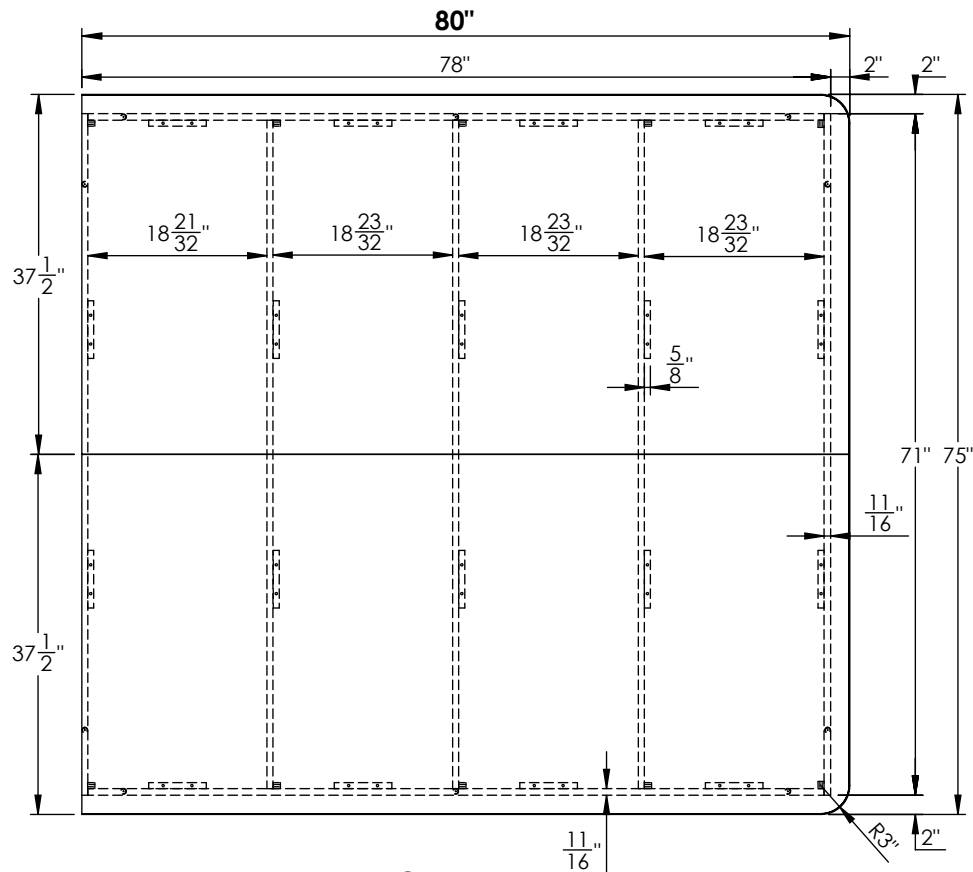

TOP VIEW

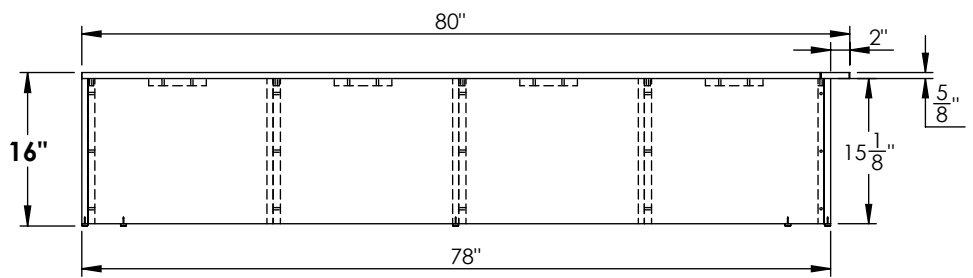

FRONT ELEVATION

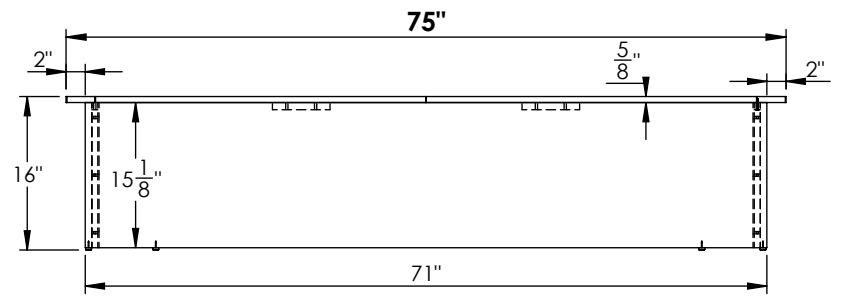

SIDE VIEW

- MATERIALS:
- HP-Laminate PLY-5/8" Side Panels
 - Plywood 5/8" Top Panel
 - T-Mold Edge On Top
 - Nail Glide On Bottom
 - Wood Framing Support

- COMMENTS:
- Overall: 75"W x 80"D x 16"H
 - Color: Wilsonart - 0000 - Custom Laminate
 - Note: Dimensional Tolerance +/- 1/16"

TITLE: AHF 0100XX 6BB - 100Sable - King Bed Base 2" Lip
 REVISION DATE: 4/7/2022

NOTE: DESIGN AND DRAWINGS ARE PROPERTY OF DICKSON FURNITURE MANUFACTURERS LLC AND MAY NOT BE DUPLICATED OR REPRODUCED WITHOUT THE EXPRESS WRITTEN CONSENT OF DICKSON FURNITURE MANUFACTURERS LLC

QUANTITY	00
REV	A
DIMENSIONS ARE IN INCHES	

SCALE: 1:20
SHEET 2 OF 5



IMPORTANT INFORMATION

- AHF 0100XX 6BB - 100Sable - King Bed Base 2" Lip -



Lift parts with at least 2 people

+RECOMMENDATIONS:

- Read instructions before installing
- Keep area clean
- Do not drag the parts
- Do not forget to wear PPE

+PERSONAL PROTECTION EQUIPMENT (PPE)

- Hand Protection
- Eye Protection
- Waist Support Belt

Parts:

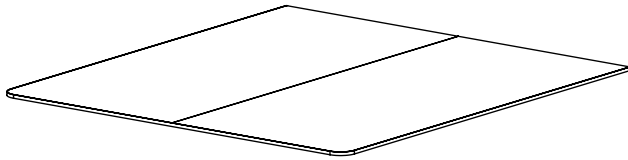

Top Panels

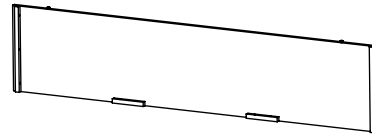

Front Panel

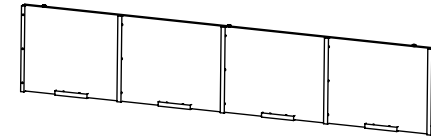

Side Panels (2)

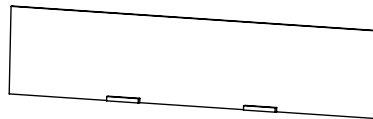

Center Panels (3)

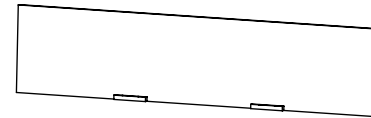

Back Panel

+Tools:



Measuring Tape



Pencil



Electric screwdriver

+Hardware:



Screw

STEP #1

ASSEMBLY INSTRUCTIONS

- AHF 0100XX 6BB - 100Sable - King Bed Base 2" Lip -

Note: For best results, bed should be built starting with the top side face down.

1

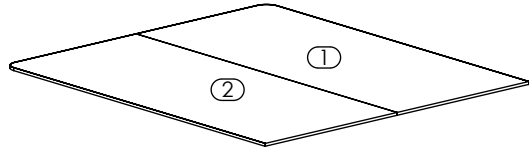

Place Top Panels ② ① upside down on Floor.

2

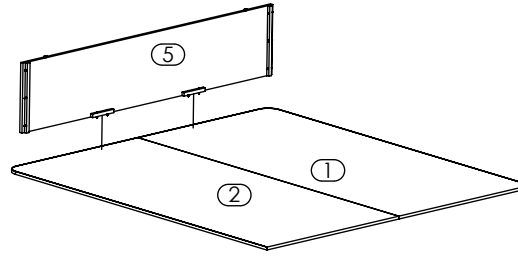

Place Front Panel ⑤ on Top Panels ① ②.

3

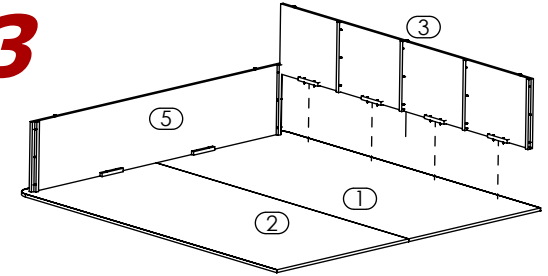

Place Side Panel Right ③ on Top Panels ① ②.

4

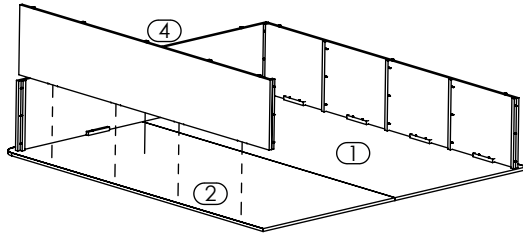

Place Side Panel Left ④ on Top Panel ① ②.

5

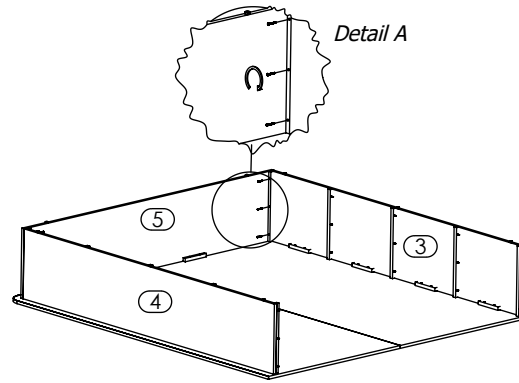

Align and attach Front Panel ⑤ to Side Panel Right ③ then Panel Left ④. (Reference Detail A).

6

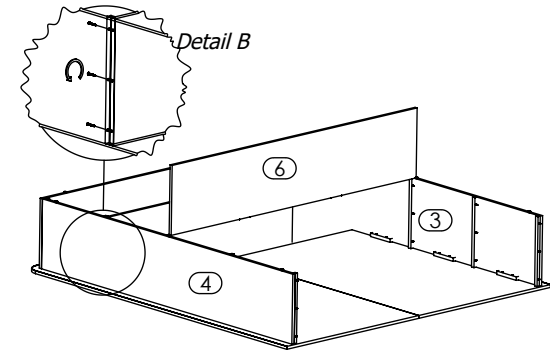

Insert Center Panels ⑥, align & attach to Side Panels ③ ④. (Reference Detail B).

7

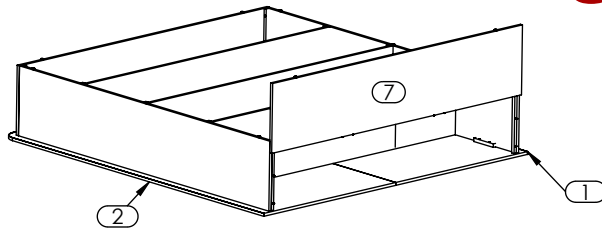

Align Flush the Back Face of Back Panel ⑦ and Top Panels ① ②.

8

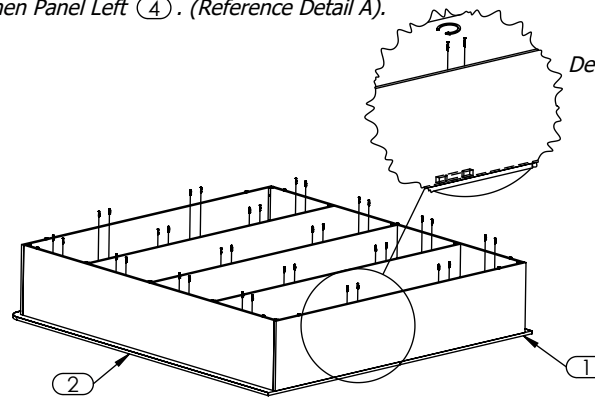

Align assembled Bed Base to taped guides on Top Panel ① and attach them. (Reference Detail C).

STEP #2

ASSEMBLY INSTRUCTIONS

- AHF 0100XX 6BB - 100Sable - King Bed Base 2" Lip -

Note: To flip this bed, please use at least 2 people.

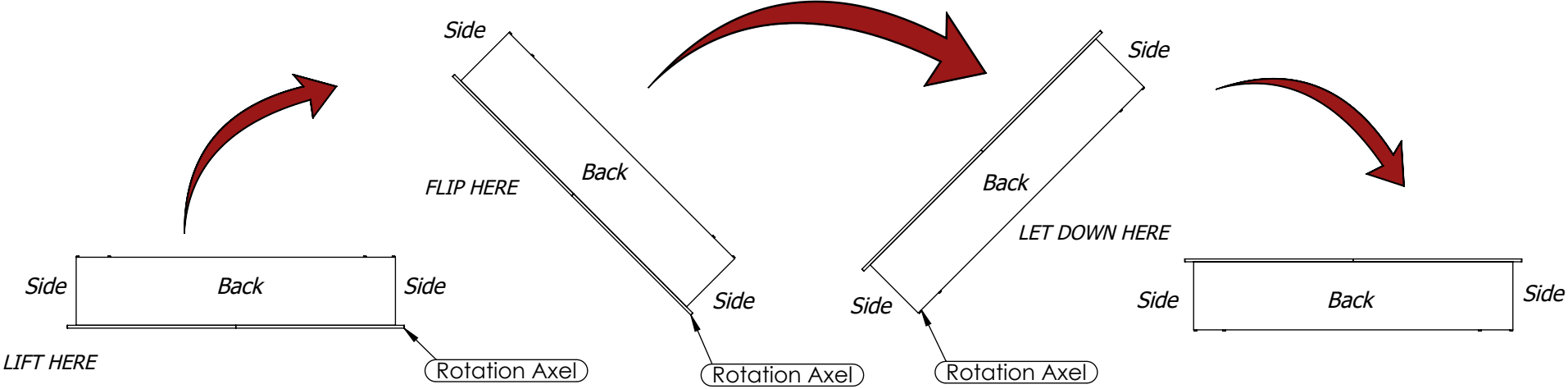

Flip Upright

